

## Data Sheet

Reference No.: 47454

## CNC dugohodni automat za struganje

Brand: CITIZEN  
Model: L 20E-2M12  
YoM, approx.: 2015 used  
Reconditioned:  
Controls:



### basic functions

number of spindles: 2

### Working Range Turning

bar diameter (max): 25 mm  
workpiece length max.: 200 mm

### main spindle

spindle revolutions (max): 10000 /min  
snaga motora: 3.7 kW

### Electrical specifications

mains power supply: 7.3 kVA  
mains voltage: 200 V

### Dimensions / weights

space requirements -left/right-: 2120 mm  
space requirements -front/back-: 1226 mm  
total height: 1752 mm  
total weight approx.: 2350 kg

### attachments (turning)

bar feeder: yes  
coolant unit: yes

### Additional Information:

ALPHA ST320 S2 Automatic magazine bar feed  
High Pressure coolant

### Seller:

Post-Venta Carreras S.A.  
Sean Gribben  
Pol. Ind. Els Plans d'Arau C/ Nicolau Copèrnic, 2, 08787  
La Pobla de Claramunt, Spain  
+34 938 088 099  
sean@prodeq.es

**Photos & Documents**

Reference No.: 47454

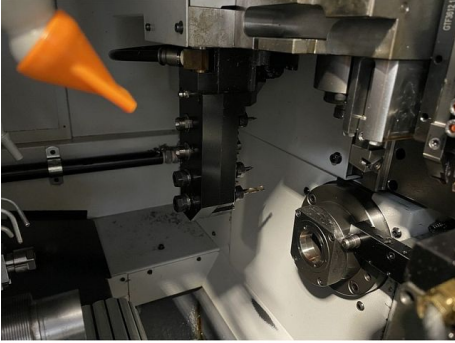

Main spindle



Spare chucks



Control Panel



Air bench



Bar feeder

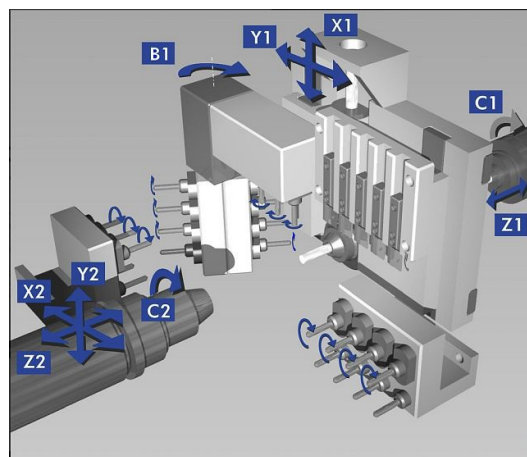

Axes